

PROCEEDINGS OF SPIE

[SPIDigitalLibrary.org/conference-proceedings-of-spie](https://spiedigitallibrary.org/conference-proceedings-of-spie)

Kinematic optimization of upgrade to the Hobby-Eberly Telescope through novel use of commercially available three-dimensional CAD package

Wedeking, Gregory, Zierer, Joseph, Jackson, John

Gregory A. Wedeking, Joseph J Zierer, John R. Jackson, "Kinematic optimization of upgrade to the Hobby-Eberly Telescope through novel use of commercially available three-dimensional CAD package," Proc. SPIE 7733, Ground-based and Airborne Telescopes III, 773342 (6 August 2010); doi: 10.1117/12.857178

SPIE.

Event: SPIE Astronomical Telescopes + Instrumentation, 2010, San Diego, California, United States

Kinematic optimization of upgrade to the Hobby Eberly Telescope* through novel use of commercially available three dimensional CAD package

Gregory A. Wedeking[†], Joseph J. Zierer, John R. Jackson
University of Texas Center for Electromechanics, 1 University Station R7000, Austin, TX 78712

ABSTRACT

The University of Texas, Center for Electromechanics (UT-CEM) is making a major upgrade to the robotic tracking system on the Hobby Eberly Telescope (HET) as part of the Wide Field Upgrade (WFU). The upgrade focuses on a seven-fold increase in payload and necessitated a complete redesign of all tracker supporting structure and motion control systems, including the tracker bridge, ten drive systems, carriage frames, a hexapod, and many other sub-systems. The cost and sensitivity of the scientific payload, coupled with the tracker system mass increase, necessitated major upgrades to personnel and hardware safety systems. To optimize kinematic design of the entire tracker, UT-CEM developed novel uses of constraints and drivers to interface with a commercially available CAD package (SolidWorks). For example, to optimize volume usage and minimize obscuration, the CAD software was exercised to accurately determine tracker/hexapod operational space needed to meet science requirements. To verify hexapod controller models, actuator travel requirements were graphically measured and compared to well defined equations of motion for Stewart platforms. To ensure critical hardware safety during various failure modes, UT-CEM engineers developed Visual Basic drivers to interface with the CAD software and quickly tabulate distance measurements between critical pieces of optical hardware and adjacent components for thousands of possible hexapod configurations. These advances and techniques, applicable to any challenging robotic system design, are documented and describe new ways to use commercially available software tools to more clearly define hardware requirements and help insure safe operation.

1. INTRODUCTION

The Hobby Eberly Telescope (HET), located at the University of Texas' McDonald Observatory in the Davis Mountain Range of west Texas, is currently being redesigned to accept a new scientific payload for its wide field upgrade to the corrector optics. The upgrade will increase the HET field of view from 4' to 22'. This will allow it to accommodate the addition of the Visible Integral-field Replicable Unit Spectrograph (VIRUS^{1 thru 10}). The upgrade results in an almost seven-fold increase in mass to the scientific payload. This mass increase as well as geometric changes necessitates a major overhaul of the tracker and drive systems for accurately positioning the wide field corrector (WFC). One of the drivers behind this upgrade is preparing the HET to execute the Dark Energy Experiment or HETDEX[‡] project²⁷. Additional information regarding the hardware changes as well as a general overview the status of the HET upgrade will be presented at the 2010 SPIE Astronomical Instrumentation Conference.^{1 thru 27}

* The Hobby – Eberly Telescope is operated by McDonald Observatory on behalf of the University of Texas at Austin, the Pennsylvania State University, Stanford University, Ludwig-Maximilians-Universität München, and Georg-August-Universität, Göttingen

[†] g.wedeking@cem.utexas.edu

[‡] <http://hetdex.org/>

Of particular interest in this paper is the hexapod assembly used to position the WFC and corrector optics located above it. The hexapod¹³ consists of six high precision linear actuators connected via universal joints at a base plate and support structure for the WFC known as the strongback as seen in Figure 1. Each actuator leg can be independently adjusted. This allows for movement in the X, Y, and Z directions as well as rotation about 3 axes yielding a full 6 degrees of freedom of movement. This large range of motion presents unique challenges in regards to predicting movement and checking for any possible component interactions over the range of motion.

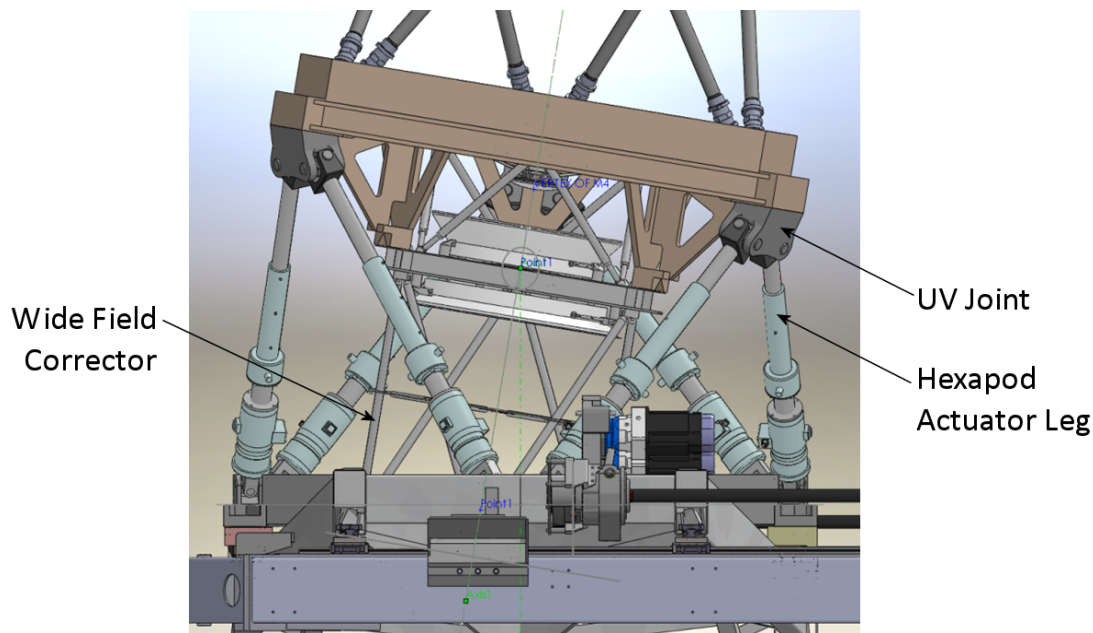

Figure 1 – Hexapod and WFC assemblies

The primary focus of the work described in this paper revolves around utilizing the SolidWorks computer aided design (CAD) software to model the motion of the hexapod assembly and ensuring the safety of the wide field corrector. The large range of possible motion allowed by the hexapod assembly's six degrees of freedom made it essential that the designers were capable of investigating that motion fully. In particular, this would allow the designers to investigate any possible hexapod positions that could lead to collisions of the WFC with the structure of the tracker bridge assembly. The complexity of the motion makes it impractical, if not impossible, to try and investigate for collisions in any sort of manual method. The need arose to automate some of the tasks related to discovering potential collision problems. A number of tools were developed to aid the designers in these tasks.

Four solutions, or tools, were developed to aid in the evaluation of the hexapod and bridge structure. First, a means of mimicking the hexapod motion prescribed by the tracker control system was developed. This allowed the designers to verify that the mechanical design matched the geometric model used in the control system. Next, a tool was developed to allow the designer to move the hexapod to various positions and inspect for any collisions or near collisions between the optical package and the tracker structure. This tool was then modified to be an automated process that used an optimization algorithm to seek out possible collision positions. Finally, expanding on the previous work, a similar tool was developed to map out the available volume beneath the WFC that would not collide with any of the tracker structure.

2. HEXAPOD MOTION CONTROL

In the simplest view, the primary purpose of the tracker system is to correctly position the optical package relative to the primary mirror. In particular, to allow it to only move to positions which maintain the optical package on axis, and at a constant distance, from the primary mirror. This leads to motion often referred to as a 'can on a string'. That is, the optical package can be visualized as a 'can' tied to a fixed point in space by a string. This fixed point in space being the spherical center of the primary mirror. In addition to this motion, the can's rotation about its own axis must be controlled as well. On the telescope, this motion is achieved by moving the tracker along its X and Y axes and then using the hexapod to lift, tilt, and twist the optical package into the proper position. The positioning of the tracker and hexapod legs are all controlled by the tracker control system. Mimicking this behavior in the CAD system was essential to ensure the final mechanical hardware would be positioning the optics where expected. A means of duplicating the control system using the tools provided by SolidWorks was necessary.

SolidWorks and other similar CAD software have tools to allow the user to limit motion of assemblies according to geometric constraints. These constraints are referred to in SolidWorks as 'mates'. These mates are mostly intended to mimic real life hardware constraints such as joints, slides, etc. SolidWorks' set of mates are geared towards allowing the solid model to move about only limited by its actual physical limitations, not an arbitrary path that might be driven by a control system. In this case, the physical constraints of the actual hardware allow for a much larger range of motion. The challenge was to determine a proper set of mates to limit the motion to that of the control system.

In general, the solution was to use the available SolidWorks mates to limit the motion of the optical package, and allow that to drive the position of the tracker and individual hexapod legs. This is effectively the opposite of what occurs with the actual hardware. Constraining the WFC to move on a spherical surface was accomplished simply by forcing it to remain a constant distance from the center of the primary mirror. Similarly, forcing its axis to always intersect that same center point was easy enough. SolidWorks allows for forcing a specific axis to remain coincident with a point in space. Controlling the rotation of the WFC about its own axis was the more difficult task, due to the fact that no ready means existed for limiting its rotation relative to its position. However, a solution was devised using what could be called 'virtual components'. These virtual components were additional empty parts that were added to the assembly that allowed for a combination of mates to be created to correctly control the rotation.

Before the addition of the rotation constraint on the WFC, the hexapod actuator lengths were found to be close to those predicted by the control system calculations, but not matching exactly. Once the set of mates were updated to include the rotation constraint the model was again checked against predicted values. The actuator lengths were then found to match exactly, within software limits, to those predicted by the control system. Once the designers had faith in the solid model accurately representing what was envisioned by the control system, further work could proceed in ensuring the safety of the scientific package carried on the WFC.

3. COLLISION DETECTION TOOL

Throughout the evolution of the tracker and hexapod design, it was often necessary to verify that no components would interfere or collide with each other. This required the designers to check for collisions. However, due to the complex movement of the hexapod, it was not an easy task. Trying to accomplish this manually proved time consuming and only a small number of possible positions could be evaluated. What was needed was a means of easily moving the hexapod to a prescribed position and then checking for interferences between the components.

The SolidWorks software package provides access to the majority of its operations through its Application Programming Interface (API). The SolidWorks API, which is defined using Visual Basic for Applications, can also be accessed through other software packages such as Microsoft Excel. A tool was developed inside of Excel which allowed the user to create a table of hexapod positions and have the software automatically move the SolidWorks solid model into those positions. The user could also prescribe any number of measurements to be taken at each of these positions.

Figure 2 shows a screenshot of the tables used in the collision detection tool. The set of columns on the left hand side contain the individual hexapod leg lengths to be evaluated. In the set of positions shown, the length of actuator leg 1 is being varied while the other five actuator lengths are being held constant. The columns on the right show measurements that are being conducted at each position. The columns labeled Test 1 are checking the distance between two components, and the columns labeled Test 2 are checking the angle between two axes. In practice, a much larger number of positions and tests would be conducted throughout the design process.

D1@Actuator 1	D1@Actuator 2	D1@Actuator 3	D1@Actuator 4	D1@Actuator 5	D1@Actuator 6	Test 1	Test 2	Test 3	Test 4	Test 5
76.2	76.2	76.2	76.2	76.2	76.2	Fail	0			
78.74	76.2	76.2	76.2	76.2	76.2	Fail	1.5			
81.28	76.2	76.2	76.2	76.2	76.2	Fail	2.9			
83.82	76.2	76.2	76.2	76.2	76.2	Fail	4.4			
86.36	76.2	76.2	76.2	76.2	76.2	Fail	5.8			
88.9	76.2	76.2	76.2	76.2	76.2	Fail	7.2			
91.44	76.2	76.2	76.2	76.2	76.2	Fail	8.6			
93.98	76.2	76.2	76.2	76.2	76.2	0.3	9.9			
96.52	76.2	76.2	76.2	76.2	76.2	1	11			
99.06	76.2	76.2	76.2	76.2	76.2	1.7	13			
101.6	76.2	76.2	76.2	76.2	76.2	2.5	14			

Figure 2 – Screenshot of collision test tool

4. OPTIMIZATION TOOL

Even with the creation of a tool to move the hexapod to a given location and identify any collisions or near-collisions, there was no guarantee that all possible collision positions could be identified. Due to the fact that there are six independently acting actuator legs it is impossible to evaluate every possible position to ensure no collisions occur. Just to check the possible positions obtained when only allowing the actuators to be fully extended or fully contracted leads to 64 unique positions. Adding the just the midpoint of the actuator’s travel, for a total of 3 positions per actuator leg, increases the number of unique positions to 729. The total number of unique hexapod positions is a simple permutation where the final number hexapod positions is equal to the number of actuator positions raised to the power of six. A more intelligent method was needed to identify any possible collision positions.

If one thinks of the shortest distance between the WFC and tracker structure as simply a function of the hexapod position, which is itself just a function of six variables, then it stands to reason that one should be able to use a mathematical optimization routine to minimize this value. In fact, this is exactly the method that was used. Excel allows a user to create a user defined function that calls an API routine. An API routine was created that would return the distance between the WFC and tracker given six actuator lengths as inputs. Using Excel’s own built in optimization tool, Solver, the software could attempt to minimize the distance between the WFC and tracker. In essence, the software would look for collisions.

The Solver routine was used to seek out possible collision locations. The collision locations found are also a byproduct of the starting hexapod position fed into the Solver. This is due to the optimization routine seeking out local minima of the distance function. Therefore, random starting positions were selected for the hexapod. After running over a thousand

random initial starting positions, the results were tabulated. In the end no actual collisions were found, but about a dozen positions were identified where the minimum distance was closer than had been found in a solely manual process.

A screenshot of the optimization tool is shown in Figure 3. The values in row 2 are the lengths of each of the actuator leg. The value of cell G2 is the measured distance between the WFC and the hexapod frame. As you can see in the formula bar, cell G2 is driven by a function called ‘Get_SW_Distance_6Mates’. This function calls an API routine which has twelve inputs. The first six are the SolidWorks distance mate names contained in row 1, and the remaining six inputs are the actual numerical values of these mates. The function returns the measured distance. The Solver Parameters window below shows the inputs for the routine. In particular, the solver is set up to vary the six actuator length cells in an effort to minimize the distance value returned in cell G2. Additionally, maximum and minimum values of the actuator lengths are set in the constraints box. The Solver Options window allows for further tuning of the routine such as maximum number of iterations to run while searching for a solution. As mentioned previously, the initial actuator lengths in row 2 were randomly assigned. For each solver run, the results were tabulated on another sheet, recording the initial lengths, final lengths, and measured distance. This output data was later post-processed to identify any positions of interest.

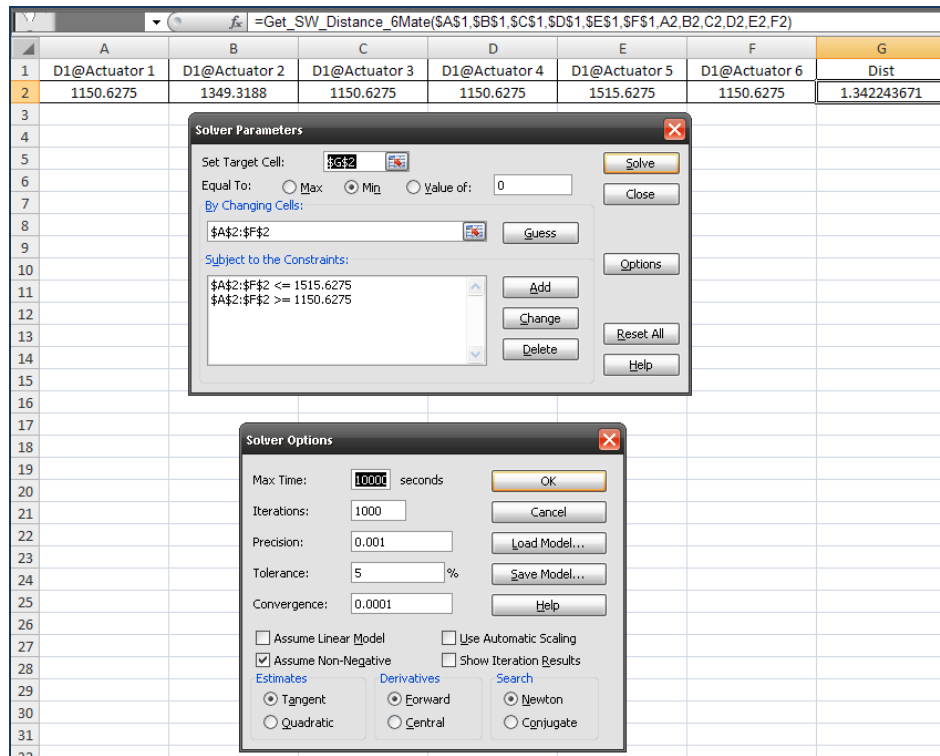

Figure 3 – Screenshot of optimization tool

For each Solver run, the software would vary the actuator lengths and call the API function to move the solid model into position so that the distance measurement could be taken. Figure 4 shows a plot of the data values during the iteration steps during one Solver run. The upper traces track the actuator positions at each iteration step and the lower trace tracks the resulting distance measurement. As you can see, in the first third of the iteration steps, the Solver algorithm is varying the actuator lengths by large amounts before settling in and approaching a minimum distance value.

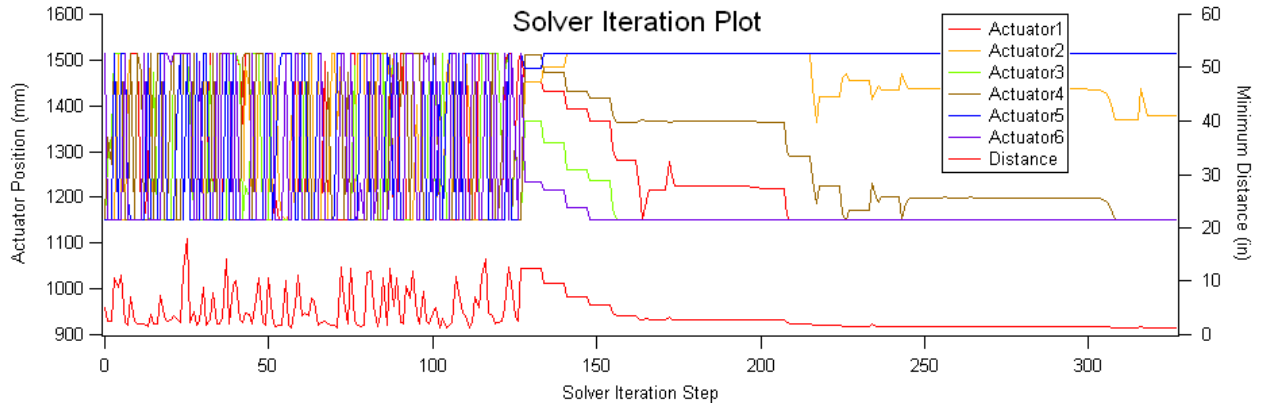

Figure 4 – Solver iteration plot, distance vs. iteration step

5. AVAILABLE VOLUME TOOL

The collision detection tool and optimization tool are both useful for seeking out hardware collisions once that hardware has been added to the solid model. However, they were only of limited value in helping make decisions about space available for hardware that had not yet been designed and modeled. In particular, the designers were interested in how much space was available below the WFC for additional hardware known as the lower instrument package (LIP). In an effort to identify what volume of space was available for the LIP, another tool was created using the SolidWorks API. This tool would attempt to define that volume accounting for full range of motion of the hexapod assembly.

The basic approach of the tool was to begin with a cylindrical volume of space below the WFC and then move the hexapod to various positions and cut away from that initial volume. By moving around to all the extreme positions of the actuators and cutting the volume, the remaining volume would be a good starting point for the designers to know approximately the shape of the available volume to place instruments without having them collide with the hexapod frame or bridge structure. In Figure 5, you can see the cylindrical volume below the WFC. Additionally, the faceted surface inside the cylinder is the resulting cut down volume created by the tool. Note this is a simplified model, and only the end connections of the hexapod legs are shown.

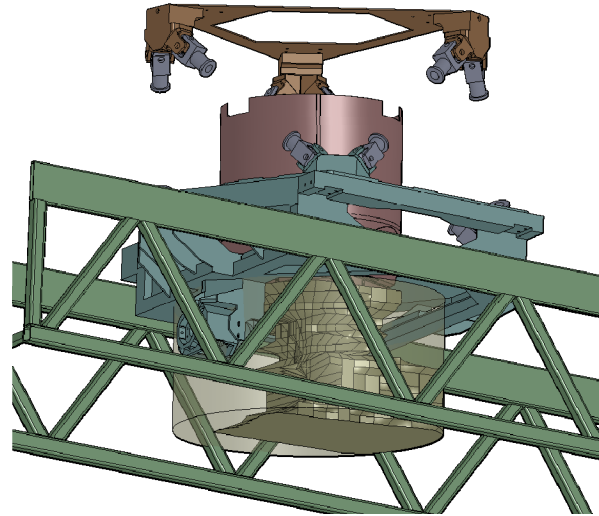

Figure 5 – Available volume below WFC

Due to a number of reasons, it was not practical to physically cut away from the initial cylinder as the hexapod positions were varied. Doing this would result in a large number of discrete volumes with highly complex surfaces. These would have been extremely computationally intensive and slow the process down or cause the software to crash. Instead a grid of radial lines was used to approximate the cylinder. Figure 6 shows a very simplified example of this radial grid. Each of the radial lines was broken into discrete segments. The hexagonal shape shown is the structure that is being tested against for potential collisions. Each of the line segments was tested against this structure to see if they intersect. All segments that intersect with the structure, and those further radially outward, are removed from the final volume. The six pointed star shape represents the remaining space that does not intersect. As you can see, the remaining space is somewhat coarse, but by increasing the number of radial lines and decreasing the length of the segments, a much closer approximation of the remaining space can be identified. Figure 7 shows a more refined set of radial line segments to define the cylindrical volume. While only shown on the top and bottom faces for clarity, the sets of radial lines would be repeated throughout the axial length of the cylinder.

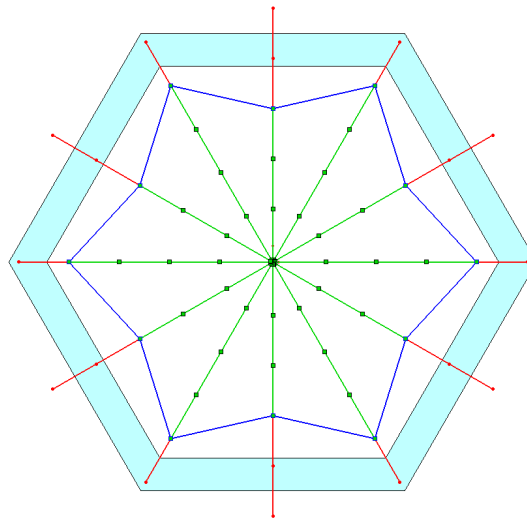

Figure 6 – Coarse model of test line segments

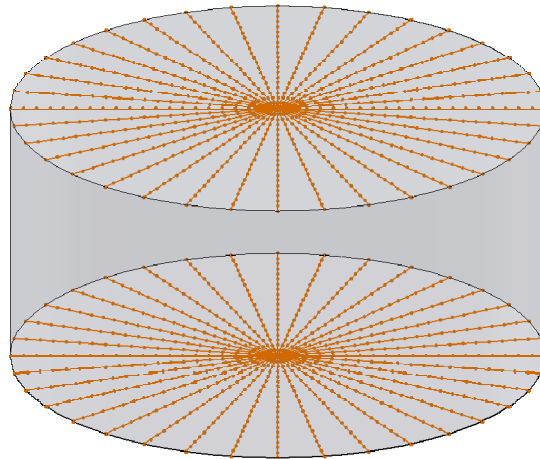

Figure 7 – Refined line segments defining cylindrical test volume

The tests described above were carried out at each of the extreme actuator locations, as well as at any of the other identified close collision positions, to define the remaining available volume. This resulted in a volume similar to the one shown in Figure 8. This volume could be used as a starting point for ensuring the hardware in the LIP would not be at risk of colliding with the hexapod frame or bridge structure. Additional available volume runs were made increasing the accuracy in the areas of most interest. Also, runs were carried out to compare the available volumes that resulted from limiting the hexapod actuators lengths to ranges set by the software limits, by the safety limit switches, and their full hardware limits. In the end, once the hardware is designed, it can be inserted into the solid model and the collision detection and optimization tests can be run to further insure that no collisions will occur.

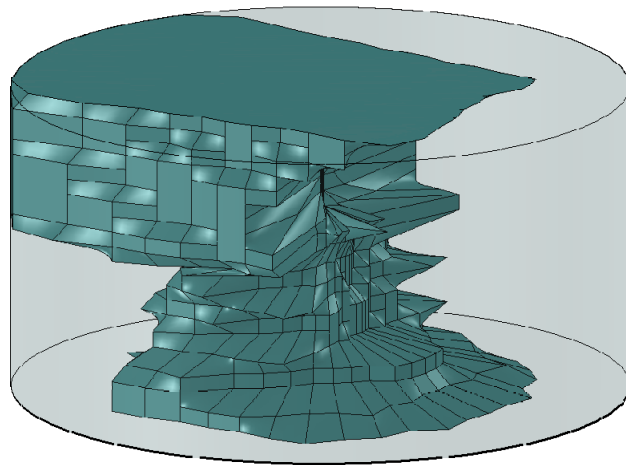

Figure 8 – Available volume study results

6. SUMMARY

The design of the HET upgrade was greatly aided by taking full advantage of some the lesser used capabilities included in the SolidWorks CAD software utilized by the designers. These capabilities allowed for exactly mimicking the control

system of the hexapod assembly to verify the solid model against the control system model. By taking advantage of the programming interface to the CAD package, a number of custom tools were designed to aid in ensuring the safety of the telescope instrumentation. A tool was created to automatically test a large number of hardware positions for any collisions as well as any other desired geometric measurements. That tool was further refined to autonomously search out any potential collisions using an out-of-the box optimization routine available in Microsoft Excel. Finally, a tool was developed to identify the volume of space available for locating additional hardware given the complex motion of the hexapod assembly. All of these combined tools allowed for a more robust design which has been much more thoroughly investigated for collisions.

ACKNOWLEDGEMENTS

HETDEX is led by the University of Texas at Austin with participation from the Universitäts-Sternwarte of the Ludwig-Maximilians-Universität München, the Max-Planck-Institut für Extraterrestrische-Physik (MPE), Astrophysikalisches Institut Potsdam (AIP), Texas A&M University, Pennsylvania State University, and the HET consortium. HETDEX is funded in part by gifts from Harold C. Simmons, Robert and Annie Graham, The Cynthia and George Mitchell Foundation, Louis and Julia Beecherl, Jim and Charlotte Finley, Bill and Bettye Nowlin, Robert and Fallon Vaughn, Eric Stumberg, and many others, by AFRL under agreement number FA9451-04-2-0355, and by the Texas Norman Hackerman Advanced Research Program under grants 003658-0005-2006 and 003658-0295-2007.

REFERENCES

- [1] G.J. Hill, et al., "VIRUS: a massively replicated 33k fiber integral field spectrograph for the upgraded Hobby-Eberly Telescope," Proc. SPIE, 7735-21 (2010)
- [2] H. Lee, et al., "LRS2: a new low-resolution spectrograph for the Hobby-Eberly Telescope and its application to scalable spectrographs for the future of extremely large telescopes," Proc. SPIE, 7735-276 (2010)
- [3] J.T. Heisler, et al., "Integration of VIRUS spectrographs for the HET dark energy experiment," Proc. SPIE, 7733-153 (2010)
- [4] I. Soukup, et al., "Design of the fiber optic support system and fiber bundle accelerated life test for VIRUS," Proc. SPIE, 7735-180 (2010)
- [5] H. Lee, et al., "VIRUS optical tolerance and production," Proc. SPIE, 7735-140 (2010)
- [6] J.L. Marshall, et al., "Production-line assembly of 150+ VIRUS spectrographs," Proc. SPIE, 7735-163 (2010)
- [7] A. Kelz, et al., "Production and performance of replicable integral field units for VIRUS," Proc. SPIE, 7735-178 (2010)
- [8] A. Collins, et al., "Development of VIRUS alignment assembly fixtures," Proc. SPIE, 7735-263 (2010)
- [9] B. Vattiat, et al., "Mechanical design evolution of the VIRUS instrument for volume production and deployment," Proc. SPIE, 7735-264 (2010)
- [10] T.S. Chonis, et al., "Development of a cryogenic system for the VIRUS array of 150 spectrographs for the Hobby-Eberly Telescope," Proc. SPIE, 7735-265 (2010)
- [11] M.S. Worthington, et al., "Design and analysis of the Hobby-Eberly Telescope Wide Field Upgrade bridge," Proc. SPIE, 7733-147 (2010)
- [12] N.T. Mollison, et al., "Design and development of a long-travel positioning actuator and tandem constant force actuator safety system for the Hobby-Eberly Telescope wide field upgrade," Proc. SPIE, 7733-150 (2010)
- [13] J.J. Zierer, et al., "The development of high-precision hexapod actuators for the Hobby-Eberly Telescope dark energy experiment (HETDEX)," Proc. SPIE, 7733-49 (2010)
- [14] J.R. Mock, et al., "Tracker controls development and control architecture for the Hobby-Eberly Telescope wide field upgrade," Proc. SPIE, 7733-152 (2010)
- [15] B.J. South, et al., "Wind loading analysis and strategy for deflection reduction on the HET wide field upgrade," Proc. SPIE, 7733-51 (2010)
- [16] M.S. Worthington, et al., "Design and development of a high-precision, high-payload telescope dual-drive system," Proc. SPIE, 7733-201 (2010)
- [17] N.T. Mollison, et al., "Collaborative engineering and design management for the Hobby-Eberly Telescope wide field upgrade," Proc. SPIE, 7738-84 (2010)

- [18] C. Ramiller, et al., "A new control system hardware architecture for the Hobby-Eberly Telescope prime focus instrument package," Proc. SPIE, 7740-129 (2010)
- [19] H. Lee, et al., "Analysis of active alignment control of the Hobby-Eberly Telescope wide field corrector using Shack-Hartmann wavefront sensors," Proc. SPIE, 7738-18 (2010)
- [20] H. Lee, et al., "Surface figure measurement of the Hobby-Eberly Telescope primary mirror segments via phase retrieval and its implications for the wavefront sensing in the new wide-field upgrade," Proc. SPIE, 7738-58 (2010)
- [21] H. Lee, et al., "Orthonormal aberration polynomials over arbitrarily obscured pupil geometries for wavefront sensing in the Hobby-Eberly Telescope," Proc. SPIE, 7738-59 (2010)
- [22] H. Lee, et al., "Metrology systems for the active alignment control of the Hobby-Eberly Telescope wide-field upgrade," Proc. SPIE, 7739-28 (2010)
- [23] J. Good, et al., "Design of performance verification testing for HET wide-field upgrade tracker in the laboratory," Proc. SPIE, 7739-152 (2010)
- [24] R. Savage, et al., "Current Status of the Hobby-Eberly Telescope wide field upgrade," Proc. SPIE, 7733-149 (2010)
- [25] A. Kelz, M. M. Roth, S. M. Bauer, B. Vattiat, E. Popow, Y. Padila, W. N. Rambold, , M. Denke, R. Haynes, G. J. Hill, J. M. Good, J. D. Murphy, R. Savage, I. Soukup, N. Mollison, "Production and performance of replicable Integral-Field Units for VIRUS", Proc. SPIE, 7735-178 (2010)
- [26] J. H. Beno, J.A. Booth, J. R. Mock, "An alternative architecture and control strategy for hexapod positioning systems to simplify structural design and improve accuracy ", Proc. SPIE, 7733-97 (2010)
- [27] G.J. Hill, et al., "The Hobby-Eberly Telescope Dark Energy Experiment (HETDEX): Description and Early Pilot Survey Results," in "Panoramic Surveys of the Universe," ASP Conf. Series, in press