

PROCEEDINGS OF SPIE

[SPIDigitalLibrary.org/conference-proceedings-of-spie](https://spiedigitallibrary.org/conference-proceedings-of-spie)

VIRUS spectrograph assembly and alignment procedures

Prochaska, Travis, Allen, Richard, Boster, Emily, DePoy, D., Herbig, Benjamin, et al.

Travis Prochaska, Richard D. Allen, Emily Boster, D. L. DePoy, Benjamin Herbig, Gary J. Hill, Hanshin Lee, Jennifer L. Marshall, Emily C. Martin, William Meador, Jean-Philippe Rheault, Sarah E. Tuttle, Brian L. Vattiat, "VIRUS spectrograph assembly and alignment procedures," Proc. SPIE 8446, Ground-based and Airborne Instrumentation for Astronomy IV, 844651 (24 September 2012); doi: 10.1117/12.925487

SPIE.

Event: SPIE Astronomical Telescopes + Instrumentation, 2012, Amsterdam, Netherlands

VIRUS spectrograph assembly and alignment procedures

Travis Prochaska^{*a}, Richard D. Allen^a, Emily Boster^a, D. L. DePoy^a, Benjamin Herbig^a, Gary J. Hill^b, Hanshin Lee^b, Jennifer L. Marshall^a, Emily C. Martin^a, William Meador^a, Jean-Philippe Rheault^a, Sarah E. Tuttle^b, Brian L. Vattiat^b

^aDepartment of Physics & Astronomy, Texas A&M University, 4242 TAMU, College Station, TX 77843-4242; ^bMcDonald Observatory, University of Texas at Austin, 1 University Station, C1402, Austin, TX, USA 78712-0259

ABSTRACT

We describe the mechanical assembly and optical alignment processes used to construct the Visual Integral-Field Replicable Unit Spectrograph (VIRUS) instrument. VIRUS is a set of 150+ optical spectrographs designed to support observations for the Hobby-Eberly Telescope Dark Energy Experiment (HETDEX). To meet the instrument's manufacturing constraints, a production line will be set up to build subassemblies in parallel. To aid in the instrument's assembly and alignment, specialized fixtures and adjustment apparatuses have been developed. We describe the design and operations of the various optics alignment apparatuses, as well as the mirrors' alignment and bonding fixtures.

Keywords: Telescopes: Hobby-Eberly, Astronomical instrumentation: Spectrographs—VIRUS, Spectrographs: Integral Field, Spectrographs: Assembly

1. INTRODUCTION

Visual Integral-Field Replicable Unit Spectrograph (VIRUS) is an instrument that will support observations Hobby-Eberly Telescope Dark Energy Experiment (HETDEX) Project¹. HETDEX will use VIRUS with the upgraded Hobby-Eberly telescope (HET) to probe for Dark Energy at high redshifts². VIRUS is comprised of 150 to 192 optical spectrographs, for which Texas A&M University is responsible for much of the manufacturing, assembly, and testing.

This paper describes conceptual and prototyped designs of the alignment fixtures³ and adjustment apparatuses that will be used to accurately and precisely align the optics in the VIRUS instrument. The alignment fixtures and apparatuses are necessary to allow the 150+ unit spectrographs to be assembled in a timely fashion and in such a way as to maximize the throughput of the instrument and therefore produce the most science possible.

1.1 Instrument Overview

The VIRUS instrument consists of between 150 and 192 simple fiber fed optical spectrographs. The unit spectrographs are assembled in pairs, and consist of a simple Schmidt spectrograph (referred to as the “collimator”) with an on-axis Schmidt vacuum camera. A volume phase holographic (VPH) grating provides a wavelength range of 350-550 nm. The detailed optical⁴ and mechanical⁵ designs of the instrument are described in more detail in other papers. The VIRUS unit spectrographs will be mounted on the sides of the telescope structure; each spectrograph is fiber-fed from the focal plane of the HET. Figure 1 shows a rendering of a pair of VIRUS unit spectrographs.

* tprochaska@physics.tamu.edu; Phone 1-979-862-2747; <http://instrumentation.tamu.edu/>

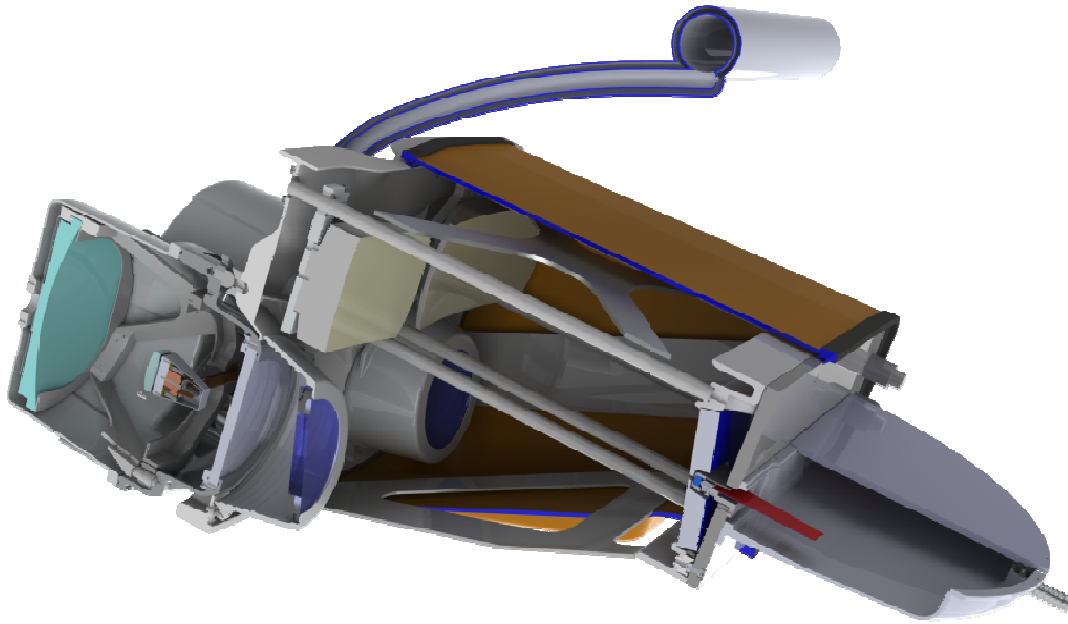

Figure 1. Section view of a pair of VIRUS spectrographs. The fiber head is shown on the right. Light from the fibers enters the instrument and is collimated by the oblong spherical collimator mirrors (upper center left). The light is reflected by a folding flat located around the fiber feed (center right), and into the grating (lower center left) which is mounted in front of the vacuum Schmidt cameras (left).

1.2 Optical Fixtures

The assembly process of the VIRUS unit spectrographs requires a precise alignment of most mechanical and optical components. This precise alignment will be accomplished by mounting each optical component in its subassembly before incorporating it into the instrument. The main fixtures under development at Texas A&M University accurately align optical components in their assemblies and are used on the collimator mirror and fold flat mirror. This paper describes the VIRUS assembly fixtures currently under design and built in preparation for the assembly of the VIRUS spectrographs.

1.3 Optical Adjustments

Several optics in the VIRUS spectrograph are designed to be adjusted after they are mounted in their assemblies. This allows the spectrograph to achieve a much greater alignment than would be possible with only fixed mechanical positioning. Having these adjustments allows the components to have looser tolerances, which decreases the cost of the instrument and number of scrapped parts. The optics that can be adjusted are the collimator mirror, the camera mirror, and the grating.

A fiducial camera and collimator is used to align the collimator mirror and camera mirror, respectively. This allows each camera and collimator to be virtually interchangeable. The grating will be adjusted to the fiducial camera, but may be readjusted once a collimator and camera are paired. This is done to compensate for potential error stack up that may cause rotational misalignments between the grating and detector.

2. OPTICAL ASSEMBLIES

2.1 Collimator Mirror Mounting System

2.1.1 Design Requirements

The collimator mirror reflects and collimates light from the fiber optics into the folding flat mirrors of the VIRUS unit. The collimator mirror will be glued to an invar puck which will allow it to be mechanically fastened to the aluminum collimator mounting plate. The collimator mirror must be attached to the puck to within 0.5 mm concentricity and $\pm 0.1^\circ$ rotation.

2.1.2 Design Solution

To meet all rotational and translational requirements, a fixture will position the mirror relative to the puck. The cylindrical and flat surfaces of the mirror will be used as the reference surfaces in the alignment fixture. As seen in Figure 2, two pins will be used along one cylindrical surface to define the mirror's X and Y position and a third pin is used along one of the flat sides to define the rotation. Clamps are also used on the opposing sides of the mirror to hold its position and rotation as defined by the pins. In the fixture assembly's current configuration the mirror's radius would have to deviate more than 0.46 mm from 147.5 mm to make the position out of tolerance. Likewise, the Y position of the referenced flat surface would have to deviate more than 0.20 mm from 66 mm to make the rotation out of tolerance.

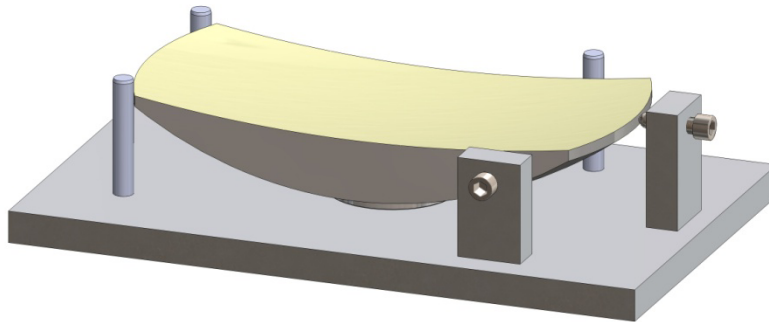

Figure 2. Fully assembled collimator mirror and puck alignment fixture.

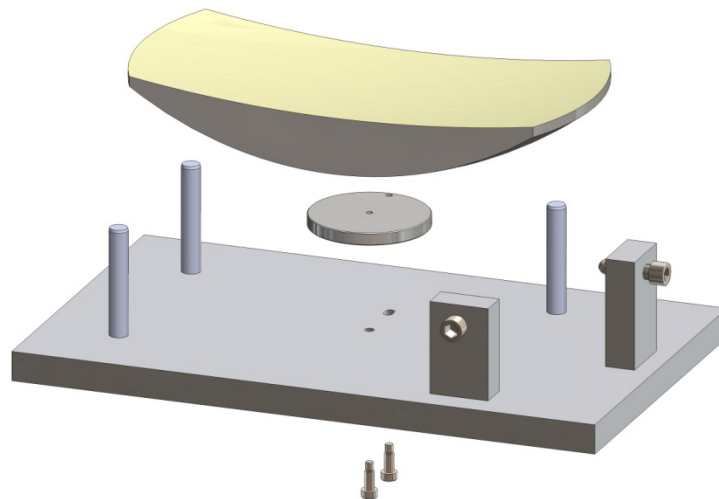

Figure 3. Exploded view of the collimator mirror and puck alignment fixture.

The puck is first aligned to the fixture using two shoulder screws to constrain its position and rotation. The outer mounting hole on the fixture is slotted to prevent the puck from being over-constrained. Next, a thin layer of epoxy, with glass beads to control the thickness, will be applied to the collimator mirror and puck. With the clamps disengaged, the mirror is placed into the alignment fixture where the mirror can slide and rotate until the epoxy is evenly spread and level. The clamp on the outer diameter is tightened first until it has a light hold on the mirror, but the mirror should still be able to rotate about its center. The clamp on the chord is engaged next until it rotates the mirror into the third pin. Both clamps are then tightened until they have a firm grip on the mirror.

The weight of the mirror provides enough compressive force to ensure the epoxy creates a proper bond, so no additional clamps or weights are needed to push down on the mirror. The epoxy will take more than a day to cure, so multiple collimator mirror fixture assemblies will be created to allow for more mirrors and pucks to be aligned and bonded concurrently.

2.2 Fold flat mounting fixture

2.2.1 Design Requirements

The fold flat mirror redirects collimated light to the grating, and has a pocket and slit cut into it where the fiber bundle emits the light through. The fold flat mirror's tip, tilt and focus is set by machined features in the head plate. To insure light from the fiber bundle is not obscured by the slit's edge and the fiber head does not hit the mirror, the mirror must be glued into its head plate so that the ends of the slots do not deviate more than 0.500 mm from its nominal position.

2.2.2 Design Solution

To satisfy this requirement, a fixture will position the fold flat mirrors relative to three vee blocks on the head plate, which connect it to the fiber bundle. This fixture references the head plate's vee blocks with three spheres, fixing the head plate in all six degrees of freedom. The fold flat mirrors are referenced by their slots via a pair of spring plungers with spherical heads to constrain the X position and rotation. Y position is constrained by a small sphere at the end of the slot. These parts are shown in Figure 4. These parts allow the mirror to conform to the tip, tilt and focus set by the head plate while the fixture sets the other degrees of freedom.

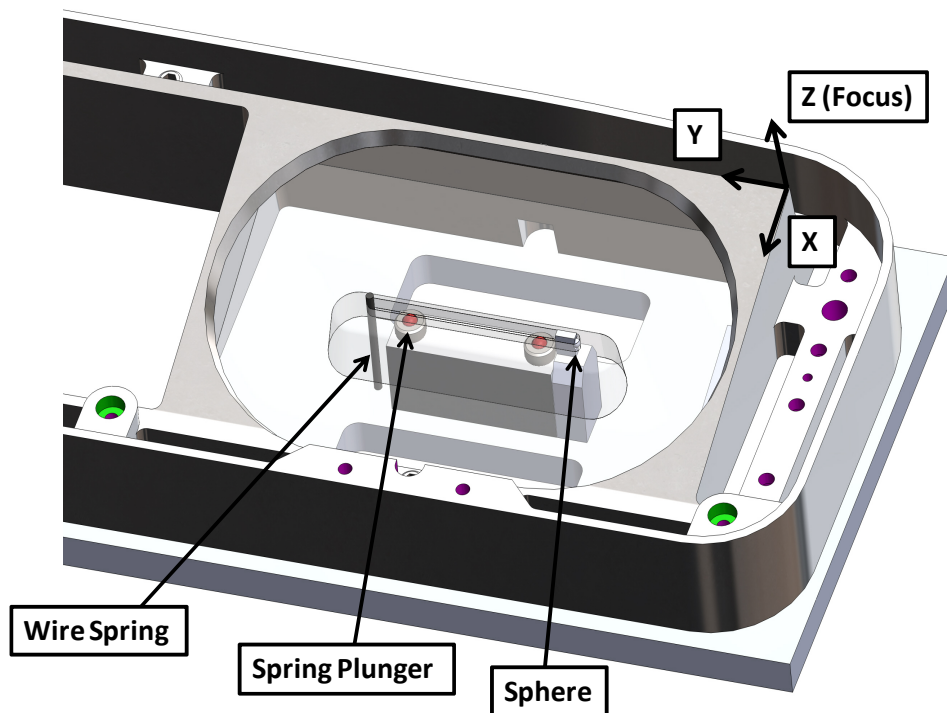

Figure 4. Rendering of the fold flat alignment fixture.

To adhere the fold flat mirrors to the head plate, RTV (DOW CORNING 7091) is used to fill in gaps between these parts. RTV is used to allow the head plate and mirrors to thermally expand and contract at different rates, without straining each other. Since the gap around the fold flat mirrors cannot be accessed while it is on the fixture, small beads of RTV are placed on the head plate near the mounting pads and corners of the mirror pockets, before inserting the mirror. This RTV will dry in a day, which allows the head plate to be removed from the fixture and flipped over. Once flipped over, more RTV can be added to the gap around the mirror, as seen in Figure 5. Current tests show the slot's position should not move more than 0.100 mm once it is removed from the fixture with RTV only on the front fixture.

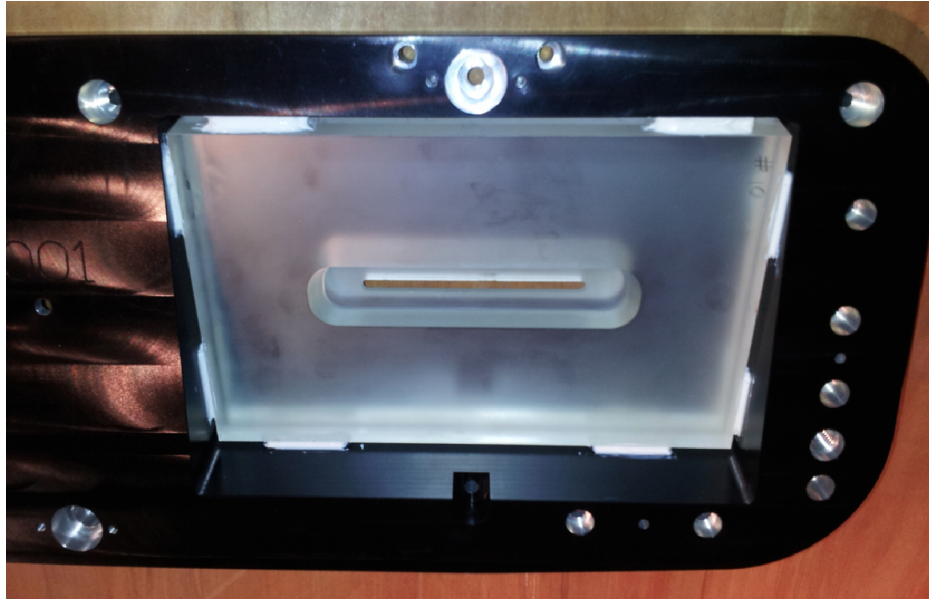

Figure 5. Fold flat mirror glued into an anodized head plate.

3. ADJUSTMENT APPARATUSES

3.1 Collimator mirror adjustment

3.1.1 Design Requirements

After the collimator mirror has been installed into the collimator assembly, its tip, tilt and focus need be adjusted until it is aligned to the fiducial camera. All the other degrees of freedom will be fixed. In order for the mirror to be accurately aligned, the resolution of the adjusters must be relatively small (less than 25 microns). Also, once the adjustments are complete the mirror's alignment must be locked.

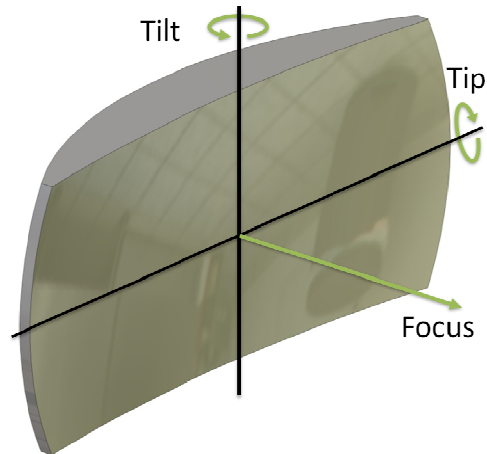

Figure 6. Illustration showing the collimator mirror's adjustable degrees of freedom.

3.1.2 Design Solutions

To adjust the tip, tilt and focus, a three point adjustment system will be used on the collimator mounting plate. This triangular plate uses slitted spherical bearings to slide each corner along an invar rod allowing it to move only in the desired degrees of freedom. Three 10 micron resolution micrometers will be threaded into the chassis and push against the collimator mirror mounting plate. Three springs on the invar rods that push back against the micrometers to preload the system. This should allow a rotational resolution of at least 1 arcsecond. All these components are shown in Figure 7.

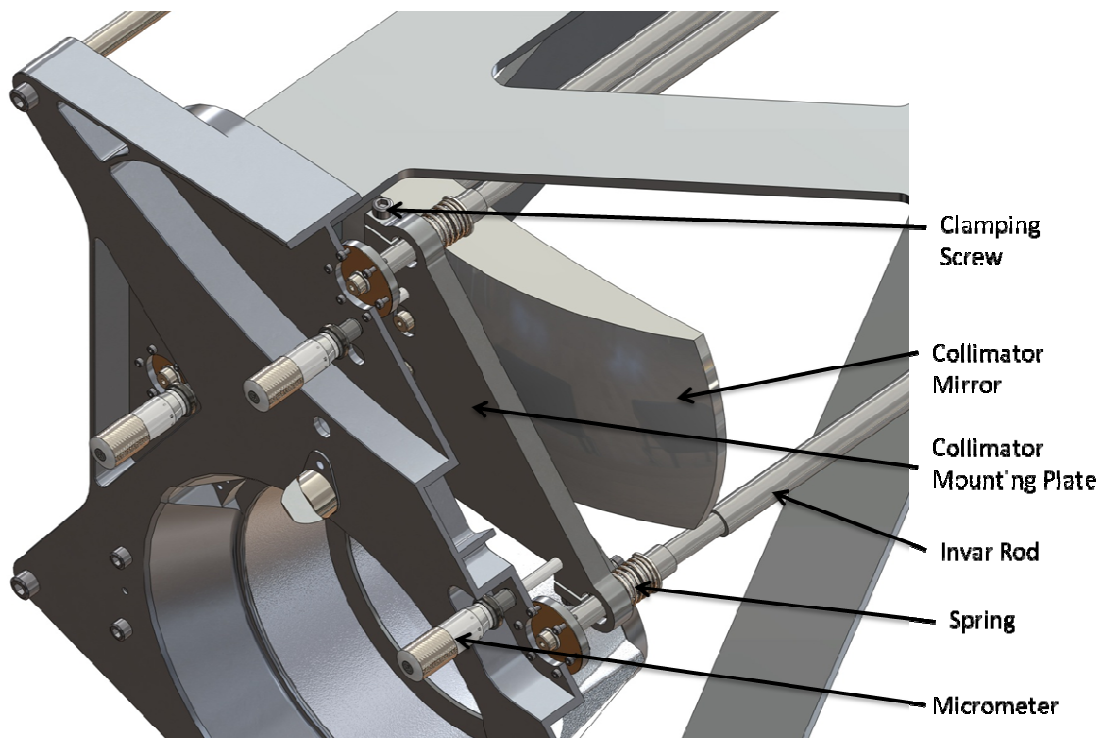

Figure 7. Section view of the collimator adjustment system.

To align the mirror, a fiducial camera and fiber bundle will be set up, and the three micrometers will be adjusted until the light on the fiber is positioned and focused on the camera's CCD within the acceptable limits. Once the mirror is aligned, three clamping screws are tightened causing the slitted bearings to clamp onto the invar rods. This fixes the mirror in place, which allows the micrometers to be removed for use on the next spectrograph.

3.2 Grating Adjustment

3.2.1 Design Requirements

It is necessary for the clocking of the grating substrate to be aligned within 0.1° of the CCD's center plane. All the other degrees of freedoms will be set by the machined features. The grating will initially be aligned to the fiducial camera's CCD, but due to mechanical tolerance stack up within the collimator and camera, the grating may have to be realigned after a collimator is paired with a camera. After adjustments are complete the grating's alignment should be locked. However, it must also have the ability to later be adjusted, in case the collimator is later paired with another camera.

3.2.2 Design Solution

To facilitate the need of adjusting the grating after the collimator and camera have been paired, the grating will be glued to a cell, which can rotate on a housing unit. The grating will be glued into its cell with RTV using a mark from the manufacturer to roughly align the grating in its cell to $\pm 1^\circ$. Two pins fixed to the housing unit will slide in arced slots in the grating cell, causing the cell to follow a circular path. The cell is kept against the housing via three hand tightened screws with lock-washers. To control the rotation of the grating a micrometer and spring plunger are mounted together to create the grating adjustment unit. This unit is temporarily fastened to the grating housing and pushes & pulls on the cell's tab to force the cell's rotation. The current model of the adjustable grating system is shown in Figure 8. Tests show this adjustment system can adjust and hold the rotation within 1 arcsecond.

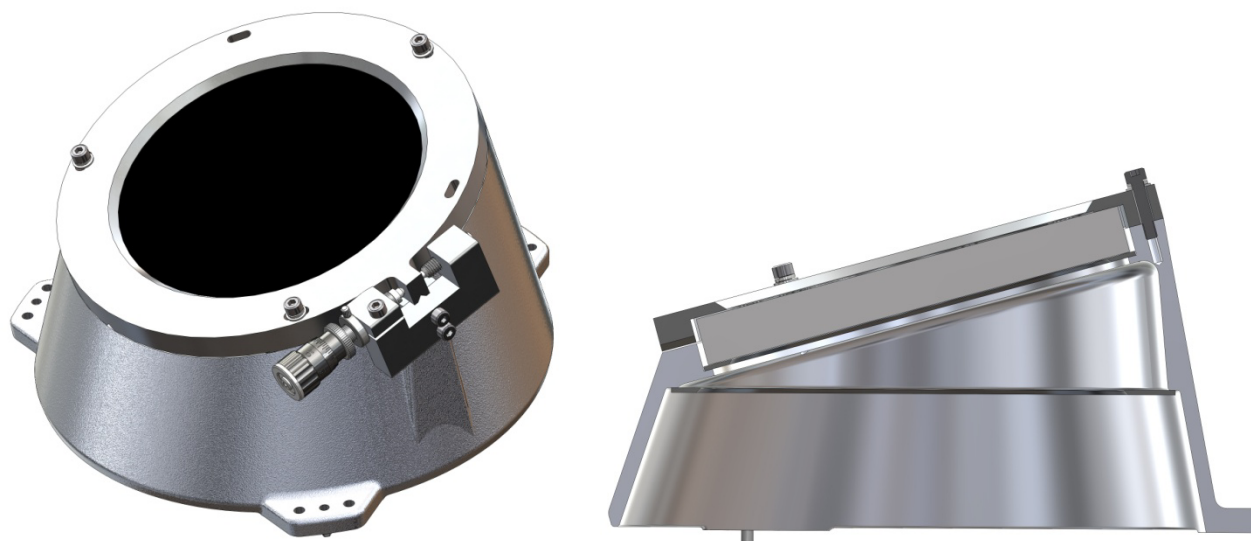

Figure 8. Isometric and section view of the adjustable grating assembly. The left model shows the grating adjustment unit, which is removed once the alignment is complete.

To align the grating, a fiber bundle is attached to the collimator-camera pair and the micrometer is adjusted until the image on the camera's CCD shows the light is properly oriented on the CCD's pixels. Software is currently being developed to assist with this alignment. Once aligned, three clamping screws are tightened to lock the rotation, and the grating adjustment unit is removed. Lastly, three beads of epoxy are applied to the edge between the cell and housing to ensure the rotation does not slip over time. If the grating ever needs to be readjusted, the epoxy can easily be tapped off with a punch and the screws loosened.

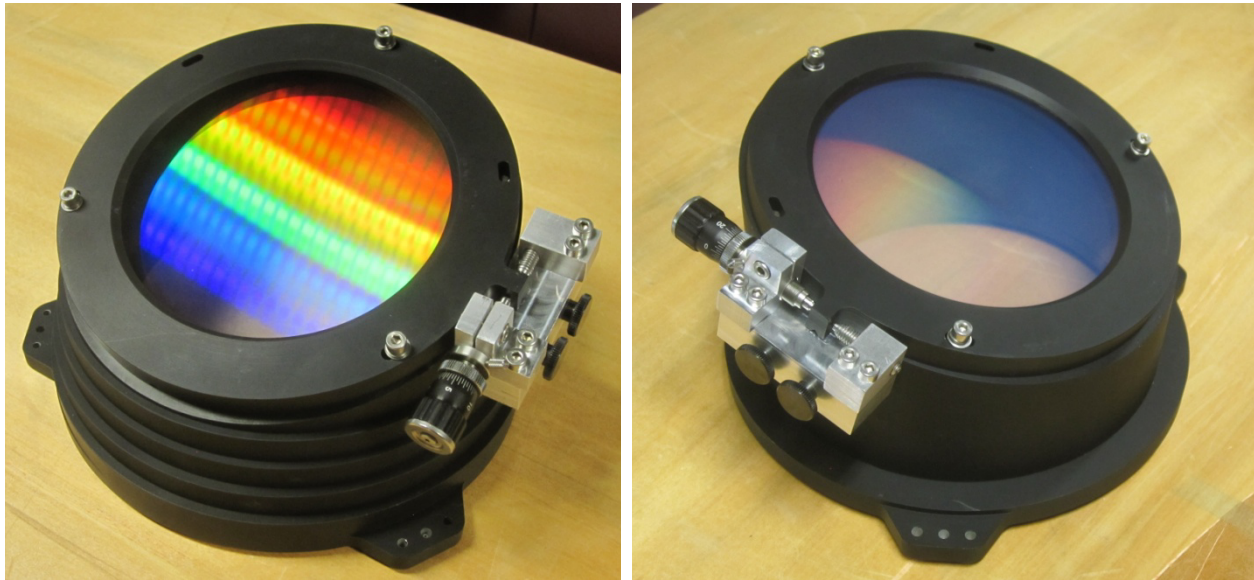

Figure 9. Two prototypes of the grating adjustment system. The housing on the left is made of a layers stacked on one another and the right housing is a simplified version made from a tube and a plate.

3.3 Camera mirror adjustment

3.3.1 Design Requirements

There is a need to adjust the camera mirror's tip, tilt, and focus to bring it into alignment with the fiducial collimator. The camera mirror redirects and focuses dispersed light from the collimator onto the detector assembly. The adjustments must be done while the camera is under vacuum and while the detector is cooled. Once the adjustment is complete the alignment must be locked, but should be capable of being unlocked and realigned if necessary.

3.3.2 Design Solutions

To adjust the tip, tilt and focus a three point adjustment system is used. Three set screws, equilaterally positioned near the mirror's edge, push against the camera mirror and the opposing spring plungers. All the other degrees of freedom are held by a flexure plate, which is glued to the top of the camera mirror. Since the adjustments must be done under vacuum, a specialized cover was made for the camera, called the adjuster back (Figure 10). The adjuster back is a modified version of a normal camera cover, which has six vacuum ports added to its back. This allows off the shelf vacuum components to attach to the adjuster back, which are used to turn the set screws under vacuum. The off the shelf parts the adjuster back uses are ferro-magnetic feedthroughs, bellows and hex keys as seen in Figure 11. The ferro-magnetic feedthroughs allow the operator to turn the set screws outside of the vacuum, and the bellows allow flexibility the hex keys' position.

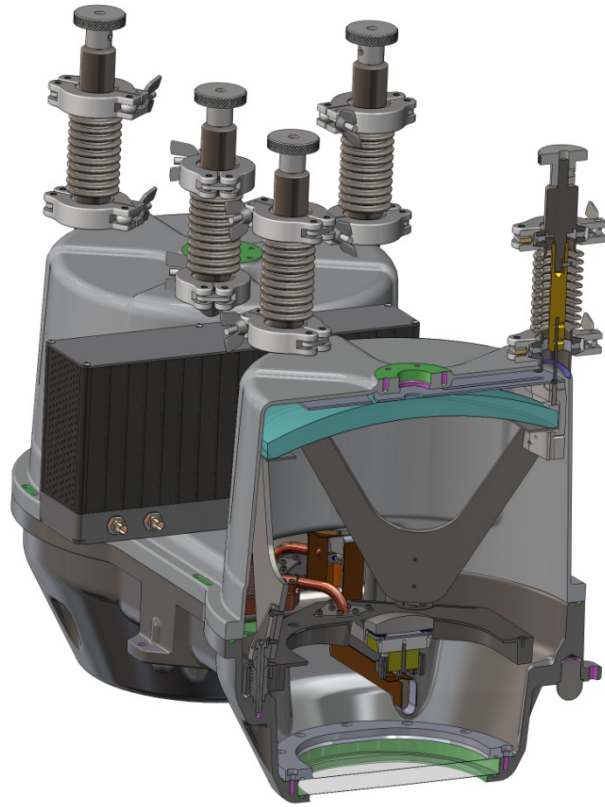

Figure 10. Assembled adjuster back on a test camera (left) and a section view of the adjuster back's model (right).

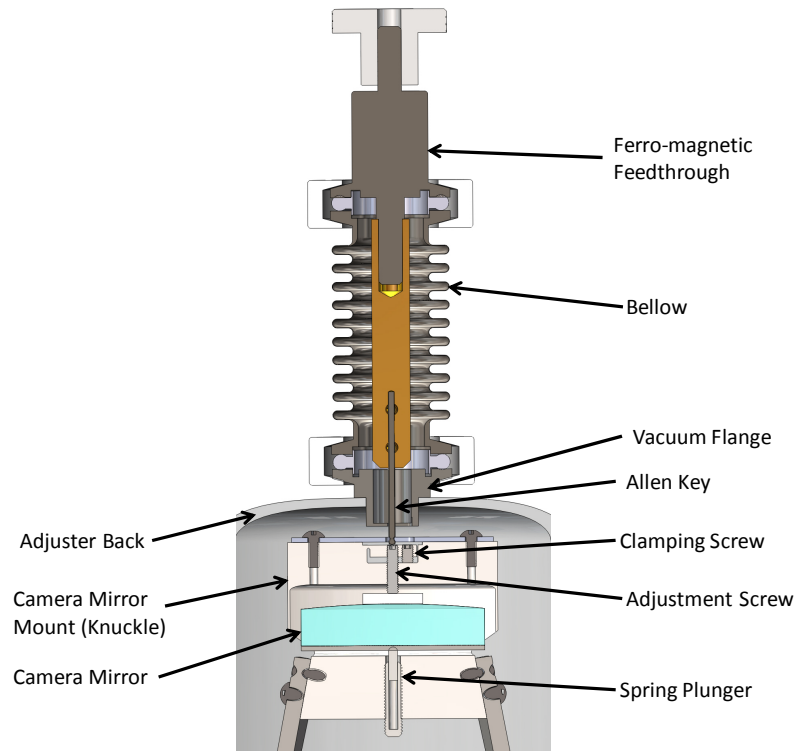

Figure 11. Section view of a feedthrough adjuster unit.

To align the camera mirror, a fiducial collimator with a fiber bundle will be set up, and the camera will be cooled and put under vacuum with the adjuster back attached. The vacuum will cause the bellows to compress, which will position the hex key nearly into the adjusting set screw. After the hex keys are fully seated, the three set screws will be adjusted until the light on the fiber is positioned and focused on the camera's CCD within the accepted limits. Once the mirror has been aligned, three clamping screws will be tightened, which will misalign the threads the adjusting screws go into, fixing the mirror in place. These clamps are seen in Figure 11 and are tightened by the same hex keys that are used for the adjustments.

4. CONCLUSIONS

The alignment and assembly fixtures described here will aid in the rapid assembly process required for producing 150+ VIRUS units. Multiple optics alignment fixtures will be manufactured so that multiple identical VIRUS sub-assemblies can be produced at once. All of these alignment components are designed to be simple to machine and to use, and should greatly reduce the time and effort required to build and align 150+ VIRUS units.

Texas A&M University is currently in the process of prototyping these fixtures and alignment systems along with the rest of the components of the unit spectrographs. Once the fixture and alignment systems are prototyped, testing will be done to determine if they meet their design requirements and if any improvements can be composed to make them easier to use. After the fixture and alignment systems are finalized, the production optics will be glued in and aligned as they arrive at Texas A&M University. Assembly and alignment is projected to take 18 months after full production starts.

ACKNOWLEDGEMENTS

Texas A&M University thanks Charles R. and Judith G. Munneryn, George P. and Cynthia W. Mitchell, and their families for their support of astronomical instrumentation activities in the Department of Physics and Astronomy.

HETDEX is led by the University of Texas at Austin with participation from the Universitäts-Sternwarte of the Ludwig-Maximilians-Universität München, the Max-Planck-Institut für Extraterrestrische-Physik (MPE), Astrophysikalisches Institut Potsdam (AIP), Texas A&M University, Pennsylvania State University, and the HET consortium. HETDEX is funded in part by gifts from Harold C. Simmons, Robert and Annie Graham, The Cynthia and George Mitchell Foundation, Louis and Julia Beecherl, Jim and Charlotte Finley, Bill and Bettye Nowlin, Robert and Fallon Vaughn, Eric Stumberg, and many others, by AFRL under agreement number FA9451-04-2-0355, and by the Texas Norman Hackerman Advanced Research Program under grants 003658-0005-2006 and 003658-0295-2007.

REFERENCES

- [1] <http://hetdex.org/>
- [2] Hill, G. J., et al., "VIRUS: a massively replicated 33k fiber integral field spectrograph for the upgraded Hobby-Eberly Telescope," Proc. SPIE, 7735-21 (2010).
- [3] Collins, A., et al. "HETDEX Development of VIRUS alignment and assembly fixtures," Proc. SPIE, 7735-233 (2010).
- [4] Lee, H., et al., "VIRUS optical tolerance and production," Proc. SPIE, 7735-140 (2010).
- [5] Vattiat, B., et al., "Mechanical design evolution of the VIRUS instrument for volume production and deployment," Proc. SPIE, 7735-264 (2010).